



# Anshun Tools Industrial Co., LTD



The hand tool and impact socket expert | Jan. 2023

# Processing Plants (1)

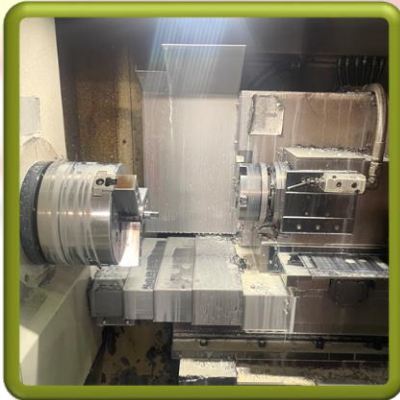

## **Lathe & CNC**

16 computerized  
lathe machines  
10 CNC machines

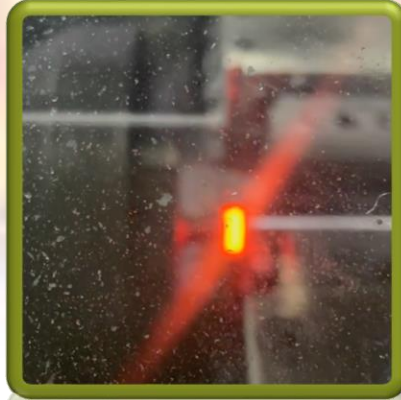

## **Friction Welding**

5 Friction welding  
machines



## **Robotic Arm**

10 robotic arm  
milling machines  
(exclusively for  
universal &  
swivel joints)

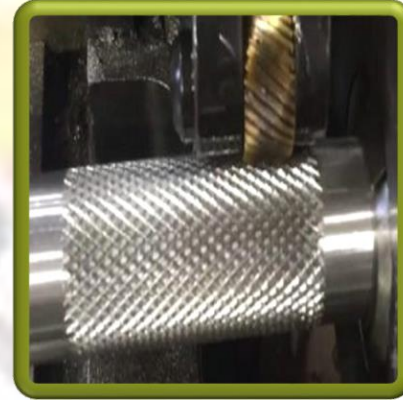

## **Knurling**

6 Knurling  
machines



## **Cold Welding**

1 Automatic Cold  
Welding Machine.  
Soon there will be  
2 more next year.



# Processing Plants (2)



**Forging**



**Heat  
Treatment**



**Vibratory  
Finish**



**Electroplating**



**Manganese  
Phosphate  
coating**

Anshun organizes processing plants to achieve optimal quality and efficiency. In about 3-5 years, we will thrive and integrate our plants into one to reach ultimate performance state.

# Anshun Factory



**Fianl Assembly  
and Packaging**

45 Skilled  
Technicians



**Sales Dept.**

2 Sales  
Representatives.

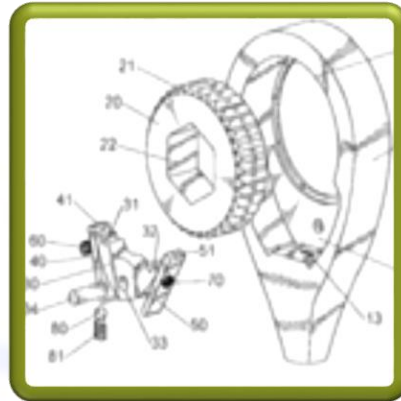

**R & D Dept.**

3 Highly  
Experienced at  
Research and  
Development



**QA Dept.**

7 Highly Skilled  
Quality Assurance  
Veterans



**Testing Dept.**

3 Well Trained  
Lab Test  
Technicians



# Test Equipment (1)



**Eccentricity  
Bench Tester**

Degree of  
parallelization:  
0.005 mm



**2 Computerized  
Torque Testing  
Machines**

D.P.I. : 1/200,000.



**Rockwell  
Hardness  
Tester**

Minimum score  
value: 0.5HR



**Salt Spray  
Corrosion Test  
Chamber**

Temp. Accuracy:  
 $\pm 0.5^{\circ}\text{C}$   
Spray volume: 0.5  
~ 3.0 ml/hr

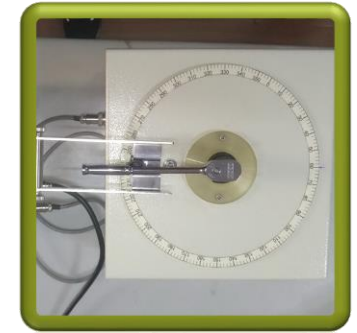

**Back Drag  
Torque Tester**

0 - 96 InOz  $\pm 3\%$

# Test Equipment (2)



**Extension Bar  
Torque Tester**

Torque Range:  
1. 0~250 ft-lb  
2. 250~1500 ft-lb



**Digital Tension  
Force Testing  
Machine**

Resolution:  
1/100,000  
Speed:  
1~1000mm/min



**Digital Moisture  
Meter**

Resolution: 0.1%  
Accuracy:  $\pm 0.5\%$   
Range: 0~99.9%



**Digital Torque  
Adapters**

Accuracy:  $\pm 2\%$   
clockwise and  
counterclockwise



**Image  
Measuring**

Scope  
Magnification  
Power: 23.5x ~  
148x  
For ICON items



# Production Process (1)



1. Steel Cutting

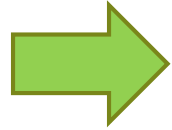

2. Cold and Hot Forging

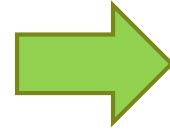

Check Point 1:  
After Forging: Before proceed to machining, our production inspectors uses gauges to check if their dimensions are within tolerances.

# Production Process (2)



3. Machining



**Check Point 2:**  
Regular Production: After machining, there are gauges available next to lathes. The machine operators do the random checking.

ICON Production: The machine operators do 100% inspection via checking equipment. They have to make sure no flaws found before moving on to next step. Same policy applies to breaker bars and ratchet wrenches.





# Production Process (3)

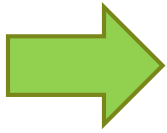

4. Grinding

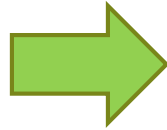

5. Knurling

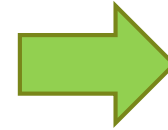

6. Stamping

# Production Process (4)

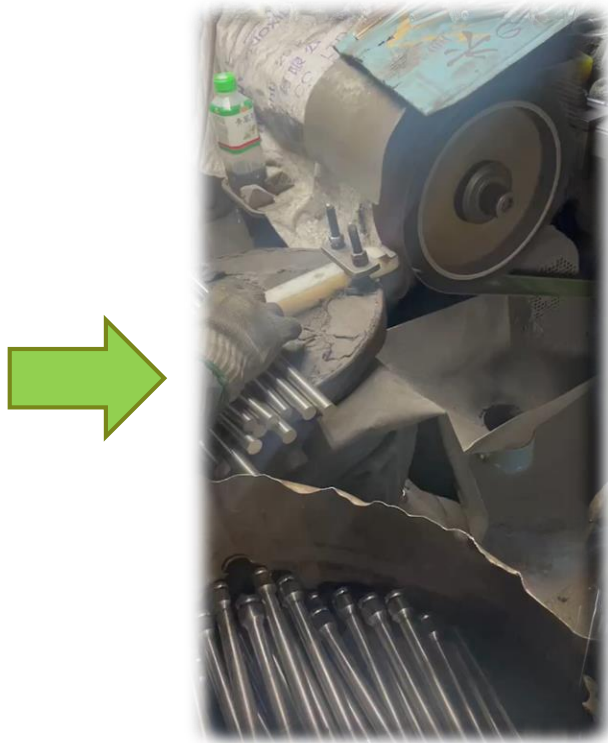

7. Belt Polishing

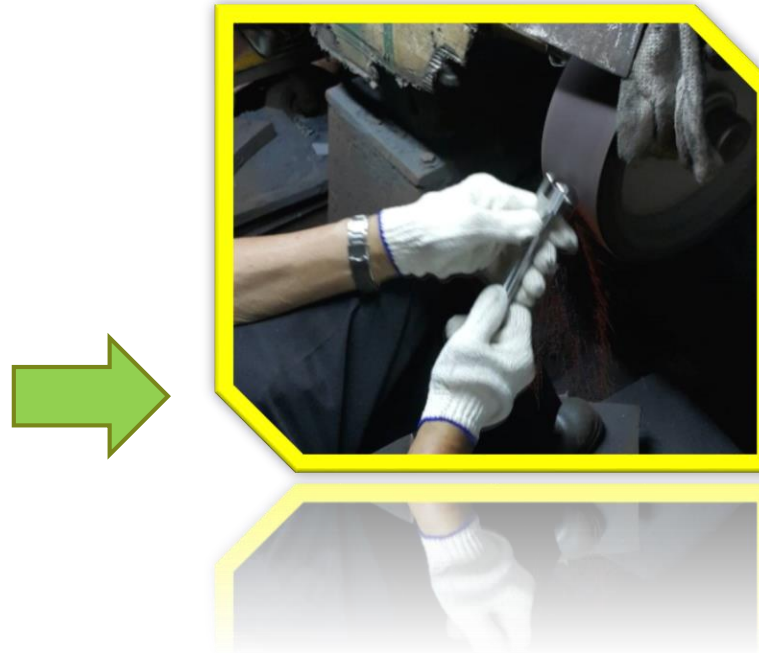

Check Point 3:  
Belt Polishing: Our production  
inspectors go there check the  
quality everyday.



8. Heat Treating



# Production Process (5)



Check Point 4:  
Hardness Check: After about 210 minutes of heat treatment, it must fall within range of 38-50HR. Both plant technicians and our inspectors ensure the hardness meets specifications before allowing it to go through next step.



Check Point 5:  
Strength Test: Both plant technicians and our inspectors ensure the hardness meets specifications before allowing it to go through next step.



After initial checks at process plants, we haul back ICON products back to our plant for thorough inspections.

# Production Process (6)



## Check Point 6:

For ICON products, we haul all of them back and do 100% checks on flaws by using high speed computerized imaging machine on ratchet head. Also gauges are incorporated for checking size tolerances. In accordance with given instructions, we also test samples again to see their hardness fall within specs. Only the passed semi-finished products are sent to the next step.



# Production Process (7)



Check Point 7:

Vibratory Finish: Our production inspectors check the results every time.

8. Vibratory Polishing

# Production Process (8)

Chrome  
Finish



9: Electroplating

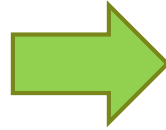

Check Point 8:

Electroplating: Chrome finish. Anshun's production inspectors take 5% samples to do pre-plating first. If the results meet requirements, then we will do the batch plating. This is to ensure quality.



# Production Process (9)

Black Phosphate



10: Black Phosphate Application



Check Point 9:  
Manganese phosphate finish: This is for impact products.  
Both plant technicians and Anshun inspectors check the final quality.

# Production Process (10)



10. Laser Etching



11. Finished products are hauled back for final inspection and packaging.



# Production Process (11)

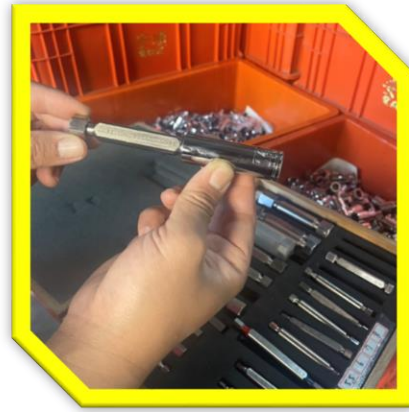
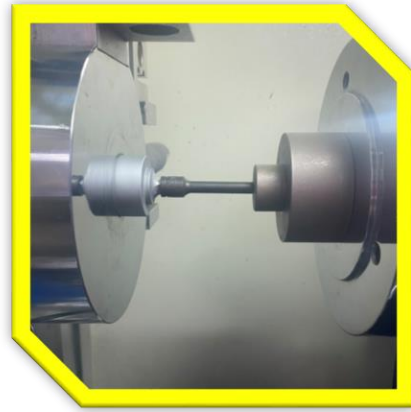

## Check Point 10:

Pre-packaging inspection. We do all the necessary checks in accordance with ICON specified requirements.

# Production Process (12)



**Check Point 11:**  
Final inspection and packaging. Our experienced technicians do 100% check on every component before it gets secured in case and then packaged properly.



# Production Process (13)



Packaged and Stacked, then loaded for shipments.



# Current Production Capacity

We are still expanding our staff and facilities to meet demands from our customers. We maintain our workloads at 70% of total production yield while we can boost 30% production any time to cater increasing orders from our customers. In addition, each year, we increase our facilities as well as production lines.





# Near Future Plans



## **On Site Swivel Socket Assembly**

ICON Item  
Assembly  
Specialists



## **Warehouse**

10700+ sqft for  
Stocking and  
Temp. Storage.



## **Anshun Fleet**

Careful Drivers  
Haul Products  
Efficiently with  
Swiftness.



## **Vietnam Plants**

Cater forging,  
electroplating,  
and black  
finishing needs.

# Vietnam Production Plants

*In an attempt to reduce its reliance on China, Vietnam is expected to participate more deeply in the **global value chain**.*

- Vietnam is a **fast-growing economy** and **the third biggest market in Southeast Asia**
- Geographic proximity to other high-tech supply chains in Asia - Vietnam is **the closest country to the Chinese manufacturing hub** – Shenzhen.
- Vietnam as an emerging trading link - Vietnam owns **the US' s Most Favored Nation (MFN) Status**, simplifying the trading process between the two countries. Vietnam is a member of the Association of Southeast Asian Nations (ASEAN).
- Abundant and low-wage workforce - Vietnam' s minimum wages held steady from 2020 to 2021 and range from approximately **US\$132 to US\$190** a month



# Market Trend and Reviews



Jose Meynard  
August 21 at 6:26 AM · e

Anyone in College, Alice Or kingsville TX buy the Locking Flex Head Ratchet and Bit Set, 35 Piece for me please?? Per my habor freight it won't be in stock with them for a few months, i'll pay shipping and everything and will even buy you a 6 pack!

ICON  
Locking Flex Head Ratchet and Bit Set  
35 Piece

★★★★ (191) Write a Review

This professional 35 piece bit set comes with a durable locking flex ratchet, extension and a full selection of the most commonly used bit sizes, all inside a premium case.

\$4499

Compare to \$4000 (18/21) at \$133 Save \$90.01

In-Store Only

+ Add to My List

Back In Stock Soon at New Braunfels, TX  
Store Info | Check Nearby Stores

College Station, TX (124.8 mi) In Stock Make My Store  
2408 Texas Ave S., Ste A  
Store Info

Alice, TX (133.5 mi) In Stock Make My Store  
1720 E Main Street, Suite 6-B  
Store Info

Kingsville, TX (152.3 mi) In Stock Make My Store  
2219 S Brahma Blvd #14  
Store Info



We constantly check reviews on ICON, Quinn, and Pittsburgh products and competitors' similar products. We read their feedback and comments and obtain market trends on social medias, like Facebook, Youtube, Instagram, Twitter, Reddit.....etc.

# 3/8 in. Metric Impact Swivel Socket Set, 10 Piece SKU#56696



## CUSTOMER REVIEWS

**4.9**  
Out of 5



Based on 92 Reviews

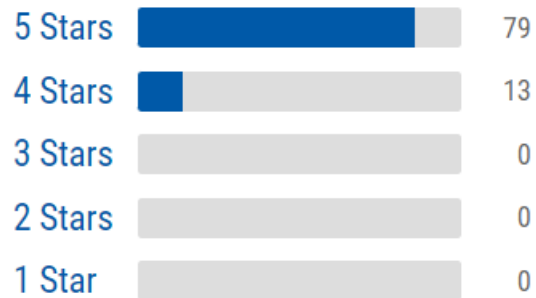

### What Customers Like Best

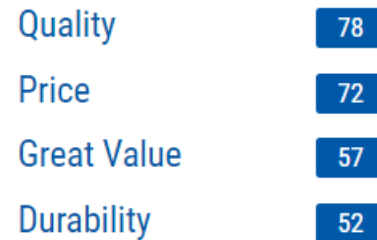

**100%**

of Customers Would Recommend This Item



# 3/8 in. SAE Impact Swivel Socket Set, 12 Piece SKU#56695



## CUSTOMER REVIEWS

**4.9**  
Out of 5



Based on 92 Reviews

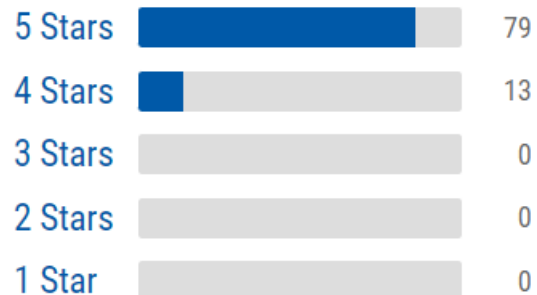

### What Customers Like Best

Price	100+
Great Value	100+
Quality	100+
Durability	100+

**100%**

of Customers Would Recommend This Item

# 1/2 in. Drive Metric Impact Swivel Socket Set, 13 Piece SKU56730



## CUSTOMER REVIEWS

**5**  
Out of 5



Based on 85 Reviews

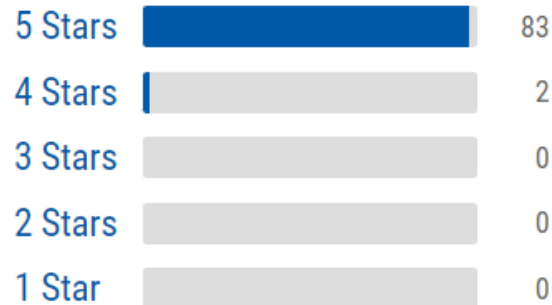

### What Customers Like Best



**100%**  
of Customers Would Recommend This Item



# 1/2 in. Drive SAE Impact Swivel Socket Set, 14 Piece SKU#56731



## CUSTOMER REVIEWS

**5**  
Out of 5



Based on 85 Reviews

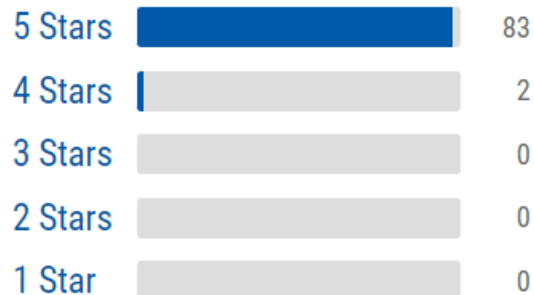

### What Customers Like Best

Quality	68
Price	62
Durability	51
Great Value	50

**100%**

of Customers Would Recommend This Item

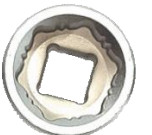

# 1/2 in. Drive SAE Impact Swivel Socket Set, 14 Piece SKU#56731



1-1/8" swivel snapped by IR 1/2" impact wrench



## 2135PTiMAX Series Impact Wrench

Powerful, durable and reliable, the 2135PTiMAX Series Impact Wrench will excel in any market.

<https://www.youtube.com/watch?v=tGgGgKB2hPs>

# 1/2 in. Drive SAE Impact Swivel Socket Set, 14 Piece SKU#56731

## 2100 MAX Series



Model	Description	Details	Handle	rpm	ft-lb (Nm)	ft-lb (Nm)	lb (kg)	in (mm)	in (mm)	in (mm)	cfm	
2125QTiMAX	1/2" Square	Hog-ring, Quietool,	Pistol	15,000	1,500	F: 277 (375) R: 332 (450)	F: 25 - 251 (34 - 340) R: 76 - 302 (103 - 410)	2.51 (1.14)	6.1 (155)	1.1 (28)	3/8 (10)	17 (481)
2125PTiMAX	1/2" Square	Pin Retainer, Quietool	Pistol	15,000	1,500	F: 277 (375) R: 332 (450)	F: 25 - 251 (34 - 340) R: 76 - 302 (103 - 410)	2.51 (1.14)	6.1 (155)	1.1 (28)	3/8 (10)	17 (481)
2135TiMAX	1/2" Square	Hog-ring	Pistol	9,800	1,250	F: 600 (813) R: 780 (1054)	F: 50 - 550 (68 - 746) R: 150 - 650 (203 - 880)	3.95 (1.79)	7.35 (186.7)	1- 3/8 (35)	3/8 (10)	24 (680)
2135QTiMAX	1/2" Square	Hog-ring, Quietool,	Pistol	9,800	1,250	F: 600 (813) R: 780 (1054)	F: 50 - 550 (68 - 746) R: 150 - 650 (203 - 880)	3.95 (1.79)	7.35 (186.7)	1- 3/8 (35)	3/8 (10)	24 (680)
2135PTiMAX	1/2" Square	Pin Retainer	Pistol	9,800	1,250	F: 600 (813) R: 780 (1054)	F: 50 - 550 (68 - 746) R: 150 - 650 (203 - 880)	3.95 (1.79)	7.35 (186.7)	1- 3/8 (35)	3/8 (10)	24 (680)
2135QPTiMAX	1/2" Square	Pin Retainer, Quietool	Pistol	9,800	1,250	F: 600 (813) R: 780 (1054)	F: 50 - 550 (68 - 746) R: 150 - 650 (203 - 880)	3.95 (1.79)	7.35 (186.7)	1- 3/8 (35)	3/8 (10)	24 (680)

The max. torque should fall around 780 ft-lb under 90psi



Turned out 160psi was incorporated



# Locking Flex Head Ratchet and Bit Set, 35 Piece SKU#58074



## CUSTOMER REVIEWS

**4.9**  
Out of 5



Based on 216 Reviews

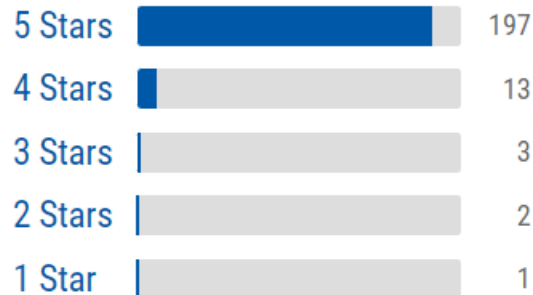

### What Customers Like Best

Quality	100+
Size/Weight	100+
Features	100+
Easy to Use	100+

**98%**

of Customers Would Recommend This Item



# Locking Flex Head Ratchet and Bit Set, 35 Piece SKU#58074



<https://www.youtube.com/watch?v=4Tq9VGItVlQ>



**True Budget EDC & Prepping** 1 個月前

Nice this is an awesome set! I've been waiting on one..great catch!

👍 1 🗨️ 回覆

▼  • 1 則回覆



**Melissa Smith** 1 個月前

I bought that a couple of months ago at Harbor Freight and the sales guy said I was lucky that they had any as they are usually out. Seems like a quality product and I am happy to have it. Thanks for the review.

👍 1 🗨️ 回覆

# 3/8 in. & 1/2 in. Professional Impact Universal Joint Adapter Set, 2 Piece SKU#56697



## CUSTOMER REVIEWS

**4.9**  
Out of 5



Based on 61 Reviews

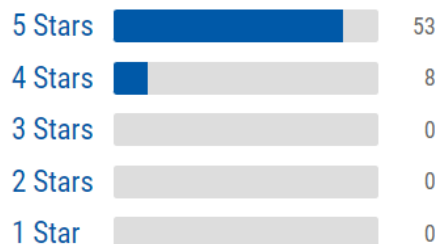

### What Customers Like Best

Quality	48
Durability	42
Price	37
Great Value	30

**100%**  
of Customers Would Recommend This Item



# 1/2 in. Drive Professional Impact Socket Extension Set, 4 Piece SKU#56884



## CUSTOMER REVIEWS

**4.9**  
Out of 5



Based on 34 Reviews

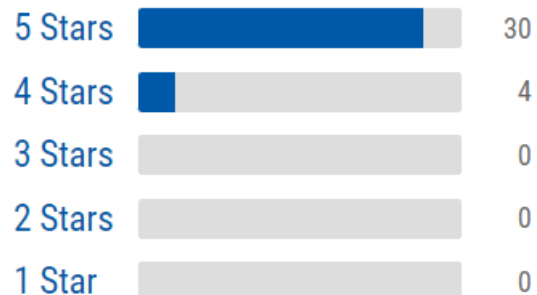

### What Customers Like Best

Price	27
Quality	26
Durability	21
Great Value	18

**100%**

of Customers Would Recommend This Item

# Professional Universal Joint Socket Adapter Set, 3 Pc SKU#57773



## CUSTOMER REVIEWS

**4.7**  
Out of 5



Based on 17 Reviews

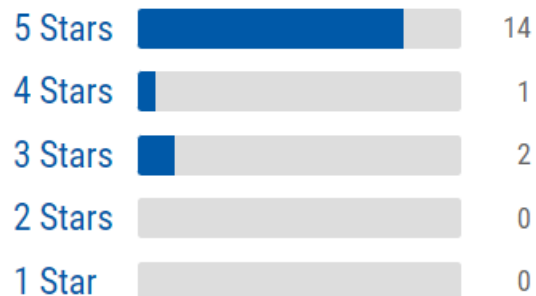

### What Customers Like Best



**94%**

of Customers Would Recommend This Item



# Professional Universal Joint Socket Adapter Set, 3 Pc SKU#57773



I DON'T LIKE USING THIS TYPE OF THING

VERIFIED BUYER

- ✓ Price
- ✓ Easy to Use
- ✓ Features

BUT SOMETIMES YOU HAVE TO

B.FRANK  
July 28, 2022

Was this helpful? 0 2 Report



Discolored finish but no issue. I hope

VERIFIED BUYER

- ✓ Recommended

Mine came with some discoloring in the finish around all of the joints in all three pieces. Will that cause any long term issues? I hope not. So far they are fine, but I'm not totally confident in them with out know why they are all discolored.

Ryan  
August 8, 2021

## Response from Harbor Freight

**STAFF**

The ICON universal joint adapters are made using a proprietary weld and polish process to ensure strength and durability. The welding process naturally changes the color of the base steel which may also change the shade of the chrome plating. Dave, Hand Tools Expert

David H.

Was this helpful? 1 1 Report



# 3/8 in. Drive 12 in. Professional Breaker Bar SKU#63855



## CUSTOMER REVIEWS

**4.8**  
Out of 5



Based on 34 Reviews

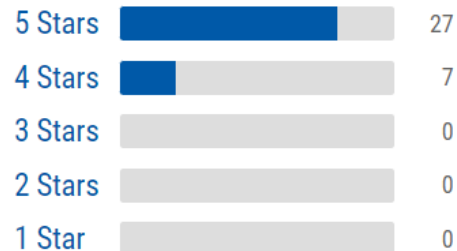

### What Customers Like Best

Price	26
Quality	25
Great Value	15
Durability	14

**97%**

of Customers Would Recommend This Item

# 3/8 in. Drive 13 in. Breaker Bar with TPR Grip SKU#63853



## CUSTOMER REVIEWS

**4.9**  
Out of 5



Based on 47 Reviews

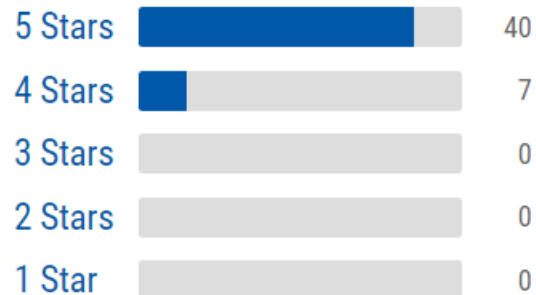

### What Customers Like Best

Quality	38
Price	33
Great Value	26
Durability	22

**100%**  
of Customers Would Recommend This Item

# 1/2 in. Drive 18 in. Professional Breaker Bar SKU#63856



## CUSTOMER REVIEWS

**4.8**  
Out of 5



Based on 71 Reviews

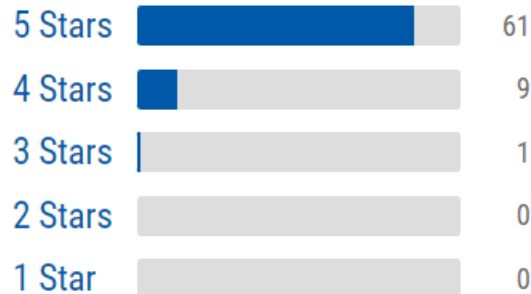

### What Customers Like Best

Quality	50
Price	48
Durability	38
Great Value	36

**100%**

of Customers Would Recommend This Item



# 1/2 in. Drive 25 in. Professional Breaker Bar SKU#64820



## CUSTOMER REVIEWS

**4.9**  
Out of 5



Based on 141 Reviews

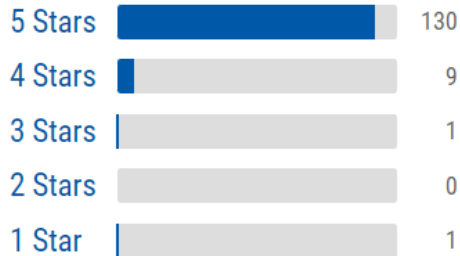

### What Customers Like Best

Quality	100+
Price	95
Durability	84
Great Value	71

**99%**  
of Customers Would Recommend This Item

# 1/2 in. Drive 25 in. Professional Breaker Bar with TPR Grip SKU#64821



## CUSTOMER REVIEWS

**4.9**  
Out of 5



Based on 154 Reviews

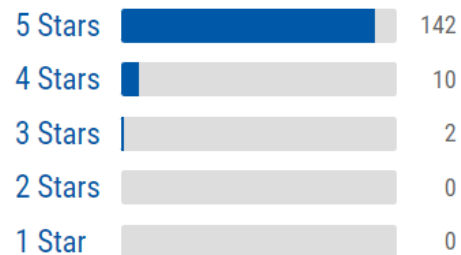

### What Customers Like Best



**100%**  
of Customers Would Recommend This Item



# 1/2 in. Drive 25 in. Professional Breaker Bar with TPR Grip SKU#64821

<https://www.youtube.com/watch?v=Zt5hqn6nEKA>



goober 7 個月前

600 is more than enough for the target demographic with HF tools. Honestly a little impressive.

👍 3 🗨️ 回覆

▲ THE PIT • 1 則回覆

THE PIT The Pit 7 個月前

Really for the money it holds up well

👍 1 🗨️ 回覆



# 3/4 in. Drive Professional 36 in. Breaker Bar SKU#63854



## CUSTOMER REVIEWS

**4.9**  
Out of 5



Based on 162 Reviews

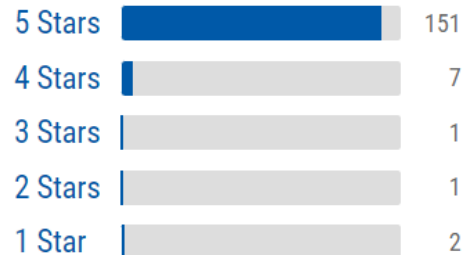

### What Customers Like Best

Quality	100+
Price	100+
Durability	100
Great Value	86

**100%**  
of Customers Would Recommend This Item

# 1/2 in. Drive SAE & Metric Master Impact Socket Set, 61 Piece SKU#58680



## CUSTOMER REVIEWS

**5**  
Out of 5



Based on 4 Reviews

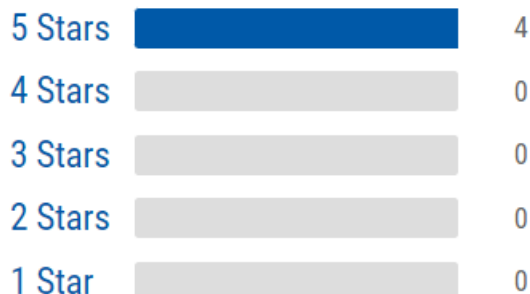

### What Customers Like Best



**100%**

of Customers Would Recommend This Item

# Master Technician Tool Set, 428 Piece SKU#58154



## CUSTOMER REVIEWS

**4.7**  
Out of 5



Based on 95 Reviews

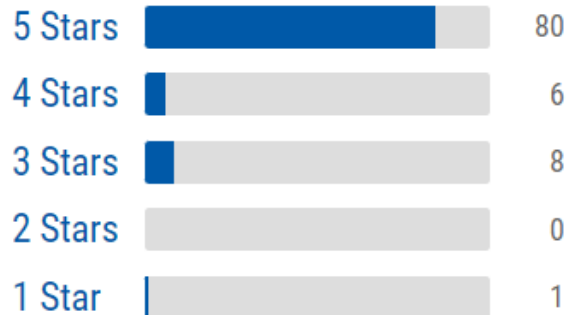

### What Customers Like Best

Price	75
Quality	72
Great Value	71
Durability	42

**98%**

of Customers Would Recommend This Item



# 10mm Metric Essential Socket Set, 10 Piece SKU#58957



## CUSTOMER REVIEWS

**4.9**  
Out of 5



Based on 98 Reviews

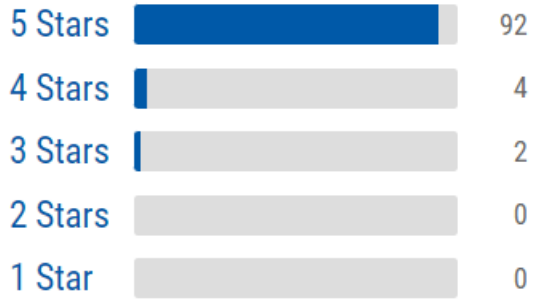

- What Customers Like Best
- Price **82**
  - Great Value **66**
  - Features **52**
  - Quality **52**

**99%**  
of Customers Would Recommend This Item



# 10mm Metric Essential Socket Set, 10 Piece SKU#58957



# Mechanics Tool Set, 225 Piece

## SKU#62664



### CUSTOMER REVIEWS

**4.8**  
Out of 5



Based on 1303 Reviews

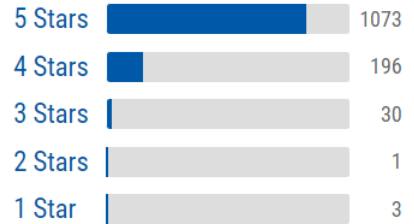

#### What Customers Like Best

- Price **100+**
- Great Value **100+**
- Quality **100+**
- Durability **100+**

**100%**

of Customers Would Recommend This Item





# Mechanics Tool Set, 225 Piece SKU#62664

**SUPER COUPON** Use Online & In-Store

**PITTSBURGH.** **LIFETIME WARRANTY** ★★★★★ (1301 reviews)

Mechanics Tool Set  
225 Piece  
SAE and Metric

**\$99<sup>99</sup>**

WAS ~~\$149<sup>99</sup>~~ **\$50 OFF**



COMPARE TO:  
KLUTCH  
48101

**SAVE \$190**

ITEM 62664



Coupon Code 36919661 **LIMIT 1** - Exp. 10/23/22\*



✓ Price

Nothing stays in place

I have 4 sets of similar tool set ups between different houses, cars, rvs , this one by far is the worst, nothing stays in place in the holders, huge mess of sockets everywhere , would not buy again

Cv

September 6, 2022

- The customer may acquire the set from another factory.
- The sockets at bottom half are not tightly clamped for easy access. The thin layer of form padding was included in the BMC keeps the sockets in place while reduce the rattling noise while transporting.



**ANSHUN**

Tools Industrial Co., Ltd  
*Specialized / Premium / Enduring*

Google

© Anshun tools



**Thank  
you**

E-mail: [as.01@anshun-tools.com](mailto:as.01@anshun-tools.com)

Tel: +8864-25603129

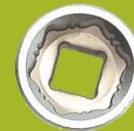

Addr: No. 3-1. Chunting 2nd St.,  
Daya Dist., Taichung City, Taiwan.